

UDC 621.873

OPTIMIZATION OF ROTATE MODE AT CONSTANT CHANGE OF DEPARTURE IN THE LEVEL-LUFFING CRANE WITH GEARED SECTOR

V.S. Loveikin¹D.A. Palamarchuk²Yu.O. Romasevych¹A.V. Loveikin³¹*National University of Life and Environmental Sciences of Ukraine*²*Kyiv National University of Construction and Architecture*³*Taras Shevchenko National University of Kyiv*

DOI: 10.32347/2410-2547.2021.106.221-235

The object of the study is a level-luffing boom system with a drive mechanism for changing the departure in the form of a toothed sector. The turning mechanism consists of a drive motor, a planetary mechanism and an open gear. Variation calculus methods were used to optimize the mode of rotation of the boom system. In this case, a variational problem is formed, which includes the equation of motion of the boom system when turning and changing the departure, the optimization criterion and the boundary conditions of motion. The Lagrange's equation of the second kind was used to compile the equations of motion. The optimization criterion is presented in the form of an integral functional, which reflects the root mean square value of the driving moment of the drive mechanism of rotation during start-up.

Key words: turning mechanism, departure change mechanism, cargo swing, steady departure change, integrated functionality, turn mode optimization.

Introduction

The level-luffing boom system is the basis of many designs of boom systems in modern cranes. Such boom system was created on the basis of the hinged four-link Chebyshev's mechanism. These level-luffing boom systems most often used in gantry cranes to perform unloading and reloading operations in ports [1].

It is well known that the delay of ships in ports is an undesirable phenomenon, as it leads to significant financial costs for both the carrier and the customer. Therefore, reducing the duration of loading and unloading of transport vessels is an urgent task. This issue is especially acute when unloading bulk cargo. This is due to the fact that in parallel with the unloading of the ship, these cargoes are loaded into railway cars or trucks.

Two schemes of unloading bulk cargo from ships and loading into wagons are most often used:

- ship, crane grab, collar, crane grab, wagon (truck);
- ship, crane grab, wagon (truck).

Each of the described systems has its disadvantages and advantages.

In the case of using the first scheme, the speed of unloading the vessel itself increases. However, this significantly increases the total duration of the unloading-loading cycle. In addition, this scheme cannot be used in small ports due to the lack of space for intermediate storage of bulk cargo. In the case of using the second unloading-loading scheme, the unloading time of the vessel increases, but the total duration of work with the cargo decreases [2].

In these cases, there is a need to combine several movements of the crane at the same time. Most often, the combination is observed during the operation of the mechanisms of changing the departure of the boom system and the crane rotation.

Horizontal movement of cargo by means of the mechanism of change of departure is a separate working movement of cranes with level-luffing boom system. This working movement can be performed independently or by combining with other working movements, depending on the technological needs during the operation of the crane.

Important problems at using of cranes during handling are the reduction of the duration of the working cycle of overloading, as well as increasing the maintenance cycle of the metal structure of the jib system and the crane as a whole. These tasks can be solved by minimizing the oscillations of the load on a flexible rope suspension.

The largest oscillations of the load on the flexible suspension are observed during the operation of the motor of the crane rotation mechanism in transient modes (start, braking) [1, 2].

Oscillations of load on a flexible suspension have a negative impact on such performance indicators of cranes as: productivity, efficiency, reliability, maneuverability, etc. [1]. The magnitude of the deviation of the cargo rope from the vertical depends on the following factors: weight of the load, speed of rotation, duration of the motor mechanism, the position of the center of mass of the load relative to the suspension point, wind loads, etc. [3, 4]. Therefore, there is a need to optimize the mode of movement of the boom system during the operation of the mechanisms of rotation and change of departure. In this case, as a rule, the operation of one mechanism is considered in the steady state of motion, and the other – in transient (start or brake) [5].

Analysis of publications

Thorough studies of the kinematics and dynamics of such a boom system were conducted in the monograph [1]. In particular, the results of studies of the movement of the boom system under different equations, corresponding to the minimization of standard deviations of displacements, speeds, accelerations and jerks of the load and the end point of the trunk. It is important that these studies were conducted when moving the cargo from the minimum value of departure to the maximum. However, the process of starting the boom system when changing the departure of the cargo was not studied.

In the article [3] the modes of movement of the mechanisms of rotation of cranes are optimized. Graphical dependences of change of kinematic and force

parameters during operation of the mechanism of rotation on transient modes of movement are constructed.

In [4] the models of possible cases of operational loading of the boom system are analyzed and constructed. The results on the operation of the mechanism of change of departure during different distribution of loads on the links of the boom system of the crane are given.

The authors of articles [5, 6] describe the ways and means of optimal control of the electric drive of the mechanism of rotation of jib cranes. In this case, the operation of electric motors is considered both during transient modes and at steady state.

In [7] the problem of optimization of loads on the links of the boom system in order to reduce the power consumption of the drive motors of the mechanism of change of departure was considered. However, the above method incompletely reveals the change of inertial forces in the unstable sections of the crane boom system.

The analysis of literature sources on research topics showed that different approaches to improving the dynamic characteristics of boom systems are proposed. However, for the most part, two ways of improving the characteristics of cranes are proposed – changing the design parameters of boom systems of cranes and means of controlling the electric motors of the actuators of cranes. In this case, the overall goal is to improve the following indicators of crane efficiency: productivity, efficiency, reliability, maneuverability, ergonomics, etc. [8...11].

Purpose and research task statement

The purpose of this study is to develop a method for optimizing the process of starting the mechanism of rotation of the level-luffing boom systems of the crane at a steady state change of departure by reducing the existing loads.

Research results

There is level-luffing boom system of a gantry crane with a toothed sector drive of the mechanism of change of departure of cargo and a planetary drive of the mechanism of turn is given (Fig. 1).

At constructing a dynamic model of the level-luffing boom system, the following assumptions are made:

- It is considered that all parts of the system are solids, except for the load, which performs pendulum oscillations on a flexible suspension;

- When changing the departure, the load moves horizontally, because the cargo rope runs along the trunk and extension and when changing the departure does not change its own length;

- We consider that the change in the departure of the boom system is carried out in a steady state, ie the angular velocity of the boom ω_0 is a constant value;

- we neglect the deviation of the cargo rope from the vertical in the plane of change of departure, only the deviation in the plane of rotation of the crane along the tangent to the trajectory of the cargo is taken into account;

– It is considered that the boom system is completely balanced by a movable counterweight.

Consider the combined movement of two mechanisms to change the departure of the load and the rotation of the crane.

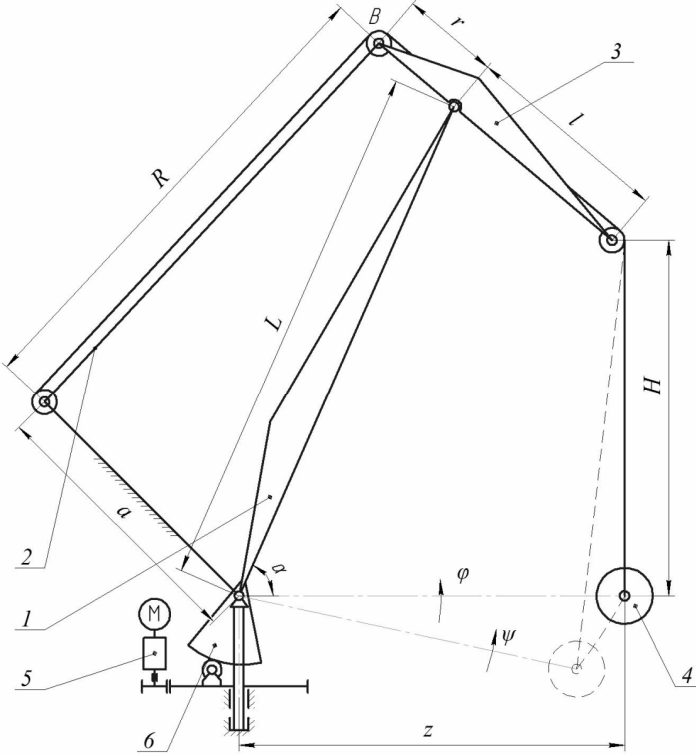

Fig. 1. Dynamic model of level-luffing boom system of the crane

1. Main jib; 2. Tieback; 3. Jib; 4. Load; 5. Rotation mechanism; 6. Outreach mechanism with gear sector

The boom system is presented as a holonomic mechanical system with three degrees of freedom. The angular coordinates of the boom in the plane of change of departure α and the angular coordinates of the rotation of the boom φ and the load ψ in the horizontal plane are taken as generalized coordinates (Fig. 2).

An elm is superimposed on the angular velocity of the boom in the plane of change of departure, as a result of which the system moves with a constant velocity $\dot{\alpha} = \omega_0 = const$. Therefore, a system with three degrees of freedom is transformed into a system with two degrees of freedom, in which the generalized coordinates will be the coordinates φ and ψ . The angular coordinate of the boom α varies according to a linear law $\alpha = \alpha_0 + \omega_0 t$, where

t is the time, α_0 is the initial position of the boom, and ω_0 is the angular velocity of its rotation in the plane of change of departure.

For such a dynamic model of motion of a level-luffing boom system, we compose differential equations of motion using the Lagrange equations of the second kind:

$$\begin{cases} \frac{d}{dt} \frac{\partial T}{\partial \dot{\varphi}} - \frac{\partial T}{\partial \varphi} = Q_\varphi - \frac{\partial \Pi}{\partial \varphi}; \\ \frac{d}{dt} \frac{\partial T}{\partial \dot{\psi}} - \frac{\partial T}{\partial \psi} = -\frac{\partial \Pi}{\partial \psi}, \end{cases} \quad (1)$$

where T – the kinetic energy of the system; Π – potential energy of the system; Q_φ – generalized component of non-potential forces reduced to the coordinate φ .

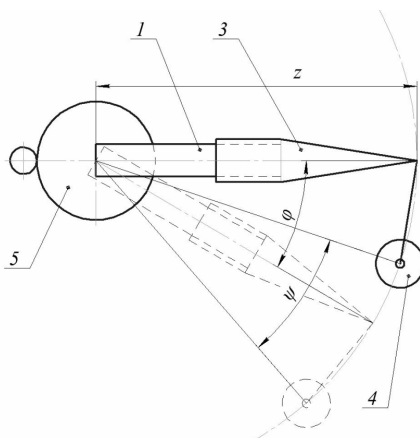

Fig. 2. The scheme of rotation of the boom system (designation of positions corresponds to Fig. 1)

Determine the kinetic energy of the boom system with the combined movement of the mechanisms of change of departure and rotation of the crane

$$\begin{aligned} T = & \frac{1}{2} (J_0 + J_C + m_X L^2) \omega_0^2 + \frac{1}{2} J_X \dot{\varphi}_X^2 + \frac{1}{2} J_B \dot{\varphi}_B^2 - \frac{1}{2} m_X L (l-r) \omega_0 \dot{\varphi}_X \cos(\varphi_X - \alpha) + \\ & + \frac{1}{2} \left\{ J_X \cos^2 \varphi_X + m_X \left[(f + L \cos \alpha)^2 + (f + L \cos \alpha)(l-r) \cos \varphi_X \right] + \right. \\ & + J_B \cos^2 \varphi_B + m_B (f - a \cos \Theta)(f - a \cos \Theta + R \cos \varphi_B) + J_P \left. \right\} \dot{\varphi}^2 + \\ & + \frac{1}{2} m (\dot{z}^2 + \dot{\psi}^2 z^2), \end{aligned} \quad (2)$$

where m_X , m_B , m – respectively, the mass of the jib, tieback and cargo; J_0 – the moment of inertia of the drive elements of the departure change mechanism, which is reduced to the axis of rotation of the boom; J_P – moment of inertia of the drive of the turning mechanism, reduced to the axis of rotation of the crane; J_C , J_X , J_B – moments of inertia about their own axes of rotation, respectively, main jib, jib and tieback; L , R – respectively, the length of the

main jib and the tieback; l, r – respectively the length of the jib and counter jib; f – the displacement of the axis of rotation of the crane relative to the lower axis of the boom hinge; a, Θ – respectively, the length of the strut and its angle of inclination to the horizon; z – the horizontal coordinate of the position of the center of mass of the load relative to the lower hinge of the boom; φ_X, φ_B – angular coordinates of rotation, respectively, the jib and tieback.

The potential energy of a fully balanced boom system is determined by the potential energy of the load

$$\Pi = mgy = mgH \left(1 - \cos \frac{z(\varphi - \psi)}{H} \right), \quad (3)$$

where g – the acceleration of free fall; H – height of the load suspension relative to the lower hinge of the boom; y – the vertical coordinate of the center of mass of the cargo.

The non-potential component of the generalized force of the turning mechanism is determined by the following dependence

$$Q_\varphi = M = M_P u \eta, \quad (4)$$

where M – reduced to the axis of rotation of the crane driving moment of the rotation mechanism; M_P – driving torque on the motor shaft of the crane rotation mechanism; u – the gear ratio of the drive of the turning mechanism; η – the efficiency of the drive in the turning mechanism.

Since the tieback has little effect on the dynamics of the boom system, therefore, $m_B = 0, J_B = 0$. We will also assume that the axis of rotation of the crane coincides with the lower hinge of the boom, so $f = 0$.

After substituting expressions (2...4) in the system (1), we obtain a system of differential equations of compatible motion of the mechanisms of change of departure and rotation of the crane

$$\begin{cases} a_1 \ddot{\varphi} - 2a_2 \omega_0 \dot{\varphi} = M - \frac{mg}{H} z^2 (\varphi - \psi); \\ mz^2 + 2mz\dot{z}\dot{\psi} = \frac{mg}{H} z^2 (\varphi - \psi). \end{cases} \quad (5)$$

Where

$$a_1 = J_P + (J_C + m_X L^2) \cos^2 \alpha + m_X (l - r) L \cos \alpha \cos \varphi_X + J_X \cos^2 \varphi_X; \quad (6)$$

$$a_2 = (J_C + m_X L^2) \sin \alpha \cos \alpha + \frac{1}{2} m_X (l - r) L (\sin \alpha \cos \varphi_X + \frac{L \sin \varphi_X}{l \cos \varphi_X} \cos^2 \alpha) + J_X \frac{L^2}{l^2} \cos \alpha \sin \varphi_X; \quad (7)$$

$$z = L \cos \alpha - l \cos \varphi_X; \quad \alpha = \alpha_0 + \omega_0 t; \quad \dot{\alpha} = \omega_0; \quad \ddot{\alpha} = 0. \quad (8)$$

$$\sin \varphi_X = \frac{1}{l} (L \sin \alpha - H); \quad \cos \varphi_X = \sqrt{1 - \frac{(L \sin \alpha - H)^2}{l^2}}. \quad (9)$$

Consider the process of starting the rotation mechanism and determine its optimal mode with a steady movement of the mechanism of change of departure. According to the criterion of the mode of movement of the turning mechanism with compatible steady motion with the mechanism of change of departure, we choose the root mean square value of the driving torque of the drive, reduced to the axis of rotation of the crane

$$M_{CK} = \left[\frac{1}{t_1} \int_0^{t_1} M^2 dt \right]^{1/2} \rightarrow \min, \quad (10)$$

where t – the time; t_1 – the duration of the start-up process.

From the first equation of the system (5) we express the driving moment of the rotation mechanism reduced to the axis of rotation of the crane

$$M = a_1 \ddot{\varphi} - 2a_2 \omega_0 \dot{\varphi} + \frac{mg}{H} z^2 (\varphi - \psi). \quad (11)$$

Also from the second equation of the system (5) we express the coordinate of the main motion of the rotation mechanism φ through the function ψ and its time derivatives

$$\varphi = \psi + \frac{H}{g} \left(\ddot{\psi} + 2 \frac{\dot{z}}{z} \dot{\psi} \right). \quad (12)$$

Differentiating the obtained expression (12) twice over time, we obtain:

$$\dot{\varphi} = \dot{\psi} + \frac{H}{g} \left\{ \ddot{\psi} + \frac{2}{z} \left[\left(\ddot{z} - \frac{\dot{z}^2}{z} \right) \dot{\psi} + \dot{z} \dot{\psi} \right] \right\}; \quad (13)$$

$$\ddot{\varphi} = \ddot{\psi} + \frac{H}{g} \left\{ \ddot{\psi} + \frac{2}{z} \left[\left(\ddot{z} - 3 \frac{\dot{z}\ddot{z}}{z} + 2 \frac{\dot{z}^3}{z^2} \right) \dot{\psi} + 2 \left(\ddot{z} - \frac{\dot{z}^2}{z} \right) \dot{\psi} + \dot{z} \ddot{\psi} \right] \right\}. \quad (14)$$

When determining the optimal mode of movement of the turning mechanism at the steady-state mode of change of departure of cargo it is necessary to set initial conditions of movement at $t = 0$:

$$\varphi(0) = 0, \quad \dot{\varphi}(0) = 0, \quad \psi(0) = 0, \quad \dot{\psi}(0) = 0. \quad (15)$$

In this case, the final starting conditions, which ensure the absence of oscillations of the load at a steady movement of the turning mechanism [12], when $t = t_1$:

$$\varphi(t_1) = \frac{\omega_p t_1}{2}, \quad \dot{\varphi}(t_1) = \omega_p, \quad \psi(t_1) = \frac{\omega_p t_1}{2}, \quad \dot{\psi}(t_1) = \omega_p, \quad (16)$$

where ω_p – the established value of the angular velocity of the crane rotation mechanism.

After substituting expressions (12...14) into equation (11), it is seen that the subintegral expression M will depend only on the unknown function and its derivatives in time up to the fourth order. Therefore, the M_{CK} functionality will, in fact, have one unknown function $\psi(t)$ as its argument.

We rewrite the boundary conditions (15) and (16) using only the function and its time derivatives. To do this, use the relations (12...14) and obtain:

$$\begin{cases} \varphi(0) = 0, \psi(0) = 0, \dot{\psi}(0) = 0, \ddot{\psi}(0) = 0, \\ \psi(t_1) = \frac{\omega_P t_1}{2}, \dot{\psi}(t_1) = \omega_P, \ddot{\psi}(t_1) = -2\omega_P \frac{\dot{z}(t_1)}{z(t_1)}, \\ \ddot{\psi}(t_1) = 2\omega_P \left[3 \frac{\dot{z}^2(t_1)}{z^2(t_1)} - \frac{\ddot{z}(t_1)}{z(t_1)} \right]. \end{cases} \quad (17)$$

Therefore, to optimize the mode of movement of the turning mechanism at a steady state change of departure of the load, an optimization problem is formulated. It includes criterion (10) in the form of an integral functional with a subintegral function (11) taking into account expressions (6...9) and (12...14) and boundary conditions of motion during start-up (17).

To approximate the solution of the nonlinear variational problem, we will represent the desired function (optimal start mode) in the form of a polynomial. Moreover, this function is divided into two terms

$$\psi(t) = \psi_0(t) + \psi_1(t), \quad 0 \leq t \leq t_1. \quad (18)$$

Here, the first term is a selected polynomial (has an explicit form) that satisfies the boundary conditions (17), and the second is a polynomial that includes free coefficients and satisfies zero boundary conditions similar to (17):

$$\begin{cases} \varphi_1(0) = 0, \psi_1(0) = 0, \dot{\psi}_1(0) = 0, \ddot{\psi}_1(0) = 0, \\ \psi_1(t_1) = 0, \dot{\psi}_1(t_1) = 0, \ddot{\psi}_1(t_1) = 0, \ddot{\psi}_1(t_1) = 0. \end{cases} \quad (19)$$

Choose ψ_0 in the form of a polynomial of degree 7 to ensure conditions (17):

$$\begin{aligned} \psi_0(t) &= t^4 \left[A_1 + A_2(t-t_1) + A_3(t-t_1)^2 + A_4(t-t_1)^3 \right], \quad 0 \leq t \leq t_1; \\ \dot{\psi}_0(t) &= 4A_1 t^3 + A_2(5t^4 - 4t^3 t_1) + A_3(6t^5 - 10t^4 t_1 - 4t^3 t_1^2) + \\ &\quad + A_4(7t^6 + 18t^5 t_1 - 15t^4 t_1^2 - 4t^3 t_1^3); \\ \ddot{\psi}_0 &= 12A_1 t^2 + A_2(20t^3 - 12t^3 t_1) + A_3(30t^4 - 40t^3 t_1 + 12t^2 t_1^2) + \\ &\quad + A_4(42t^5 - 90t^4 t_1^2 + 45t^3 t_1^2 - 12t^2 t_1^3); \\ \ddot{\psi}_0 &= 24A_1 t + A_2(60t^2 - 24t t_1) + A_3(120t^3 - 120t^2 t_1 + 24t t_1^2) + \\ &\quad + A_4(210t^4 - 270t^2 t_1^2 - 24t t_1^3 + 135t^2 t_1^2). \end{aligned} \quad (20)$$

With this choice ψ_0 , the boundary conditions (17) at the initial time $t = 0$ are already fulfilled. The coefficients A_1, A_2, A_3, A_4 are chosen so that the nonzero boundary conditions (17) are satisfied at the final moment of time $t = t_1$.

As a result of substituting conditions (17) depending on (20) we obtain:

$$A_1 = \frac{\omega_P}{2t_1^3}; \quad A_2 = -\frac{\omega_P}{t_1^4}; \quad A_3 = \frac{\omega_P}{t_1^4} \left[\frac{1}{t_1} - \frac{\dot{z}(t_1)}{z(t_1)} \right];$$

$$A_4 = \frac{\omega_P}{3t_1^4} \left[3 \frac{\dot{z}_1^2(t_1)}{z^2(t_1)} - \frac{\ddot{z}(t_1)}{z(t_1)} + 12 \frac{\dot{z}(t_1)}{t_1 z(t_1)} \right]. \quad (21)$$

Therefore, a polynomial ψ_0 of the form (20) with coefficients (21) satisfies the boundary conditions (17). We will write a polynomial ψ_1 in a kind

$$\psi_1(t) = t^4 (t - t_1)^4 (C_0 + C_1 t + \dots + C_n t^n), \quad 0 \leq t \leq t_1. \quad (22)$$

The multiplier $t^4 (t - t_1)^4$ guarantees the fulfillment of zero boundary conditions at any values of the coefficients C_0, \dots, C_n . These coefficients remain free, and are used to find the minimum of the functional M_{CK} .

Substituting dependences (20) with coefficients (21) and dependence (22) into expression (18), we obtain an explicit form of the function ψ , which includes free coefficients C_0, \dots, C_n , and it follows from the construction that the obtained function ψ will satisfy the boundary conditions (17) at random choice C_0, \dots, C_n . Having an explicit form of the function ψ , we can find the form of the function φ using dependence (12). The function φ will also include free coefficients C_0, \dots, C_n . Next, substituting φ , ψ in expression (11) we obtain the expression for the moment M , which is included in the subintegral expression of the functional M_{CK} (10). After the integration, in expression (10) the functional M_{CK} will depend on the free coefficients C_0, \dots, C_n , because the functional M_{CK} is considered as a function of arguments C_0, \dots, C_n . Therefore, the approximate solution of the variational problem (10) taking into account (6...14) and boundary conditions (17) is reduced to finding the minimum of the function of many variables, for this we can use one of the approximate methods [13, 14]. In this work, an application package was used to solve this problem, in which methods based on the simplex method were used to find the minimum function of many variables.

To determine the derivatives $\dot{\psi}, \dot{\psi}', \dot{\varphi}, \dot{\varphi}'$ included in (11...14), approximate formulas of numerical differentiation were used, namely, symmetric difference derivatives of the first and second orders, and to approximate the integral (1) – the trapezoidal formula.

The selected in (22) maximum exponent $n=5$. For the required functions ψ , φ , their derivatives and for the driving moment M (11) calculations are performed, the results of which are shown in Fig. 3...6. These calculations were performed for the crane boom system with the following parameters [15]: $\alpha_0 = 0,9$ radian, $\omega_0 = 0,0278$ radian/s, $\omega_P = 0,157$ radian/s, $t_1 = 4$ s,

$L = 25,76 \text{ m}$, $l = 10,16 \text{ m}$, $r = 2,51 \text{ m}$, $H = 14,7 \text{ m}$, $g = 9,81 \text{ m/s}^2$,
 $m = 20000 \text{ kg}$, $m_X = 5453 \text{ kg}$, $J_C = 2,856 \cdot 10^6 \text{ kg m}^2$, $J_X = 1,189 \cdot 10^5 \text{ kg m}^2$,
 $J_P = 6,338 \cdot 10^5 \text{ kg m}^2$.

In fig. 3 shows graphs of changes in the angular coordinates of the rotation of the boom system and the load. These graphs show a smooth change of angular coordinates, but there is a deviation of the coordinates of the boom system and the load, which is eliminated before the start of the start-up process, and when entering the steady state coordinates coincide.

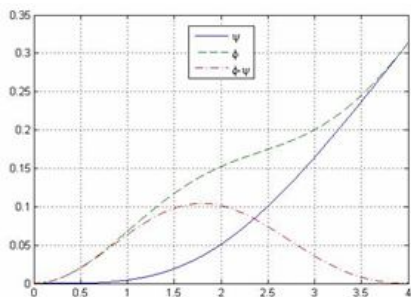

Fig. 3. Graphical dependence of coordinates

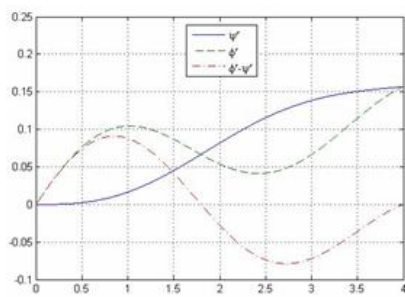

Fig. 4. Graphical dependence of velocities

In fig. 4 shows the dependences of the angular velocities of the boom system and the load when turning the crane. From these graphs it is seen that the speed of the load during the start-up process gradually increases, and in the speed of the boom system there are some fluctuations. At the end of the start-up process, the angular velocities of the boom system and the load coincide, as in their movements. This indicates that there will be no pendulum oscillations of the load on the flexible suspension in the area of steady movement of the turning mechanism.

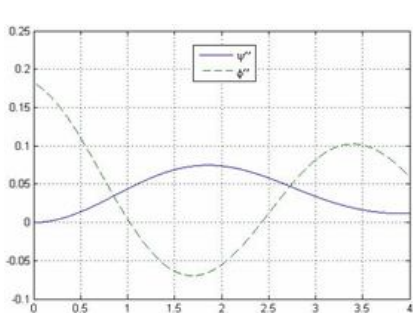

Fig. 5. Graphical dependence of accelerations

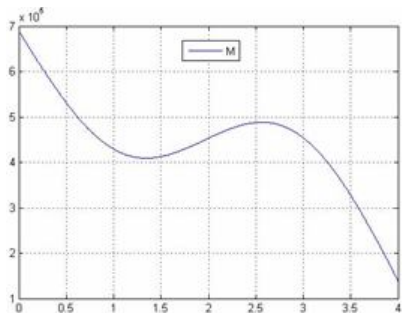

Fig. 6. Graphical dependence of torque

In fig. 5 shows the graphical dependences of the angular accelerations of the load and the boom system, which shows that the acceleration of the load increases smoothly and decreases from zero initial value to a small value at the

end of the start. However, the acceleration of the boom system at the beginning of the movement increases rapidly to the maximum value with subsequent change with oscillations.

A similar situation is observed when changing the dynamic component of the driving moment of the drive mechanism (Fig. 6). At the initial moment of start the driving moment of a drive of the mechanism of turn sharply increases to the maximum value with its subsequent decrease with some fluctuations. A sharp change, at the beginning of the movement, leads to oscillations in the system, to reduce which it is necessary to ensure a smooth change of driving momentum. However, this mode of movement increases the start-up time, which reduces the performance of the crane.

Conclusions

1. In the considered article the optimization problem of joint movement of mechanisms of change of departure and turn of a boom system of the crane is set. In this case, the change of load departure is carried out in a steady state at a constant angular velocity of the motor shaft, and rotation during start-up, when the motor shaft changes its angular velocity from zero to a fixed value.

2. The optimization problem includes a mathematical model of the joint movement of the mechanisms of change of departure and rotation of the crane, the optimization criterion, which is the RMS value of the driving torque of the rotation mechanism during start-up and boundary conditions of movement that eliminate load oscillations on a flexible suspension. process.

3. The nonlinear optimization problem is solved by an approximate method, where the solution is represented as a polynomial with unknown coefficients, which are determined using a package of applications based on the simplex method.

4. As a result of solving the optimization problem, the graphical dependences of the kinematic characteristics of the boom system and the load, as well as the driving moment of the drive of the turning mechanism during start-up are constructed. The obtained optimal mode of crane rotation during start-up at the steady-state mode of departure change allowed to eliminate load oscillations on a flexible suspension and to minimize dynamic loads in the drive mechanism.

5. Recommendations for the possible application of a certain optimal mode of joint movement of the mechanisms of change of departure and rotation of the jib system of the crane in practice in limited operating conditions.

REFERENCES

1. *Loveikin V.S., Palamarchuk D.A.* Optymizatsiya rezhymiv rukhu sharnirno-zchlenovanoi strilovoyi systemy krana (Optimization of modes of movement of the articulated boom system of the crane). – Kyiv : Publisher TsP «KOMPRINT», 224 p.
2. *Palamarchuk D.A., Kim A.O., Sysolyatina L.D.* Vykorystannya kraniv z sharnirno-zchlenovanoju strilovoyu systemoyu u perevantazhuvalnykh kompleksakh (Using of cranes with level-luffing jib system in reloading complexes). 14th International Symposium of Ukrainian Mechanical Engineers in Lviv: materials of the symposium. Lviv: KINPATRI LTD, 2019. P. 114–115.

3. *Loveikin V.S., Chovnyuk Yu.V., Kadikalo I.O.* Optimizatsiya rezhymiv rukhu mekhanizmiv obertannya vantazhopidymnykh kraniv (Optimization of modes of movement of mechanisms of rotation of cranes). Scientific Bulletin of the National University of Life and Environmental Sciences of Ukraine. Series: machinery and energy of agro-industrial complex. Kyiv. 2017. Vol. 262. P. 177–190.
4. *Bortyakov D.E., Nekrasova A.V., Sokolov S.A.* Modelirovaniye ekspluatatsionnoy nagruzhennosti elementov portal'nykh kranov (Modeling the operational loading of gantry crane elements). Scientific and technical bulletin of the St. Petersburg State Polytechnic University, 2008. No. 60. P. 203–211.
5. *Gerasimyak R.P., Togobitskiy A.L., Naidenko E.V.* Optimal'noye upravleniye elektroprivodom mekhanizma povorota (Optimal control of the electric drive of the rotation mechanism). Collection of materials of the V International (XVI All-Russian) scientific conference. S. Petersburg, 2007. P. 384–387.
6. *Limonov L.G., Netesa A.N., Kreslavsky A.I., Teslitsky A.N.* Elektroprivody peremennogo toka osnovnykh mekhanizmov portal'nogo krana s greyferym i kryukovym zakhvatom (AC electric drives of the main mechanisms of the gantry crane with grab and hook gripper). Electrical engineering and electrical equipment, 2006. No 66. P. 138–140.
7. *Loveikin V.S., Palamarchuk D.A.* Issledovaniye dvizhushchikh sil v mekhanizme izmeneniya vyleta strelovoy sistemy krana (Investigation of driving forces in the mechanism of changing the outreach of the boom system of the crane). Allukrainian collection of scientific works "Mining, constructional, road and melioration machines", 2014. Vol. 84. P. 39–45.
8. *Naidenko O. V., Makhortova D. O.* Keruvannya elektroprivodom mekhanizmiv obertannya z urakhuvannyam pidvishenoho vantazhu (Control of the electric drive of mechanisms of rotation taking into account the suspended load). Electrical and computer systems, 2010. No01 (77). P. 17–26.
9. *Zairulazha Bin Zainal.* Modeling and Vibration Control of a Gantry Crane. Faculty of Electrical Engineering Universiti Teknologi Malaysia, 2005. 160 p.
10. *Noriaki Miyata, Tetsuji Ukita, Masaki Nishioka, Tadaaki Monzen, Takashi Toyohara* Development of Feedforward Anti-Sway Control for Highly efficient and Safety Crane Operation. Technical Review, 2001. Vol. 38 No. 2. P. 73–77.
11. *Keqin LI, Cuxiang Jiang* Inverse design of a new double-link luffing mechanism and realization on MATLAB. Proceedings of the 3rd ICMEM International conference on mechanical engineering and mechanics. October 21–23, 2009. Beijing, P. R. China. P. 301–304.
12. *Loveikin V. S., Romasevich Yu. O., Kadikalo I. O.* Obhruntuvannya krayovykh umov rukhu v zadachi optymizatsiyi rezhymu povorotu strilovoho krana (Substantiation of boundary conditions of movement in the problem of optimization of the mode of rotation of the jib crane). Lifting and transport equipment, 2019. No. 2 (61) P. 45–59.
13. *Lyashko I. I., Boyarchuk A. K., Guy Ya. G., Golovach G. P.* Spravochnoye posobiye po vysshey matematike (Reference book in higher mathematics) Moscow. Editorial URSS, 2001. 360 p.
14. *Tslaf L. Ya.* Calculus of variations and integral equations. St. Petersburg: Lan, 2005. 192 p.
15. *Erkki Salminen* Big is Beautiful. Konecranes' world, 2002. No7. – P. 3–5.

Стаття надійшла 02.03.2021

Ловеїкін В.С., Паламарчук Д.А., Ромасевич Ю.О., Ловеїкін А.В.

ОПТИМІЗАЦІЯ РЕЖИМУ ПОВОРОТУ КРАНА ПРИ УСТАЛЕНІЙ ЗМІНІ ВІЛЬОТУ ШАРНІРНО-ЗЧЛЕНОВАНОЇ СТІЛОВОЇ СИСТЕМИ ІЗ ЗУБЧАСТИМ СЕКТОРОМ

Наведено результати оптимізації режиму повороту шарнірно-зчленованої стрілової системи крана на ділянці пуску, при усталеному режимі зміни вильоту. За об'єкт дослідження використано стрілову систему з секторним приводом механізму зміни вильоту, а механізм повороту складається з електродвигуна, планетарного механізму та відкритої зубчастої передачі. Для оптимізації режиму повороту стрілової системи використані методи варіаційного числення. При цьому, сформовано варіаційну задачу, яка включає рівняння

руху стрілової системи при повороті та зміні вильоту, критерій оптимізації та крайові умови руху. Критерій оптимізації має вигляд інтегрального функціоналу, що відображає середньоквадратичне значення рушійного моменту приводного механізму повороту за час пуску. Дослідження проведено на ділянці пуску електродвигуна механізму повороту від стану спокою до досягнення номінальної частоти обертання та при усталеній швидкості обертання електродвигуна механізму зміни вильоту.

Розв'язок задачі представлено у вигляді полінома з двома доданками, перший з яких забезпечує крайові умови руху, а другий мінімізує критерій оптимізації через невідомі коефіцієнти. Для цього використано пакет програм, що базується на симплекс методі. Побудовано графіки зміни кінематичних характеристик вантажу та стрілової системи при роботі механізмів повороту та зміни вильоту, а також рушійного моменту в процесі пуску механізму повороту, які відповідають оптимальному режиму руху. Отриманий режим руху дозволив усунути коливання вантажу на підвісі та мінімізувати дію динамічних навантажень. На основі досліджень розроблено рекомендації щодо використання отриманого оптимального режиму пуску.

Ключові слова: механізм повороту, механізм зміни вильоту, розгойдування вантажу, усталена зміна вильоту, інтегральний функціонал, оптимізація режиму повороту.

Loveykin V.S., Palamarchuk D.A., Romasevich Yu.O., Loveykin A.V.

OPTIMIZATION OF ROTATE MODE AT CONSTANT CHANGE OF DEPARTURE IN THE LEVEL-LUFFING CRANE WITH GEARED SECTOR

The results of optimization of the rotation mode of the level-luffing boom system of the crane at the launch site, with the steady-state mode of departure change. The object of the study is a boom system with a sector drive of the mechanism of change of departure. The mechanism of rotation consists of an electric motor, a planetary mechanism and an open gear. Variation calculus methods were used to optimize the mode of rotation of the boom system. In this case, a variational problem is formed, which includes the equation of motion of the boom system when turning and changing the departure, the optimization criterion and boundary conditions of motion. The optimization criterion has the form of an integral functional that reflects the root mean square value of the driving torque of the drive mechanism of rotation during start-up. The study was carried out at the starting point of the electric motor of the turning mechanism from the state of rest to reach the nominal speed and at a steady speed of rotation of the electric motor of the mechanism of change of departure. The solution of the problem is presented in the form of a polynomial with two terms, the first of which provides boundary conditions of motion, and the second minimizes the criterion of optimization through unknown coefficients. To do this, use a software package. Graphs of change of kinematic characteristics of cargo and boom system at work of mechanisms of turn and change of departure, and also the driving moment in the course of start of the mechanism of turn which correspond to an optimum mode of movement are constructed. The resulting mode of movement allowed to eliminate the oscillations of the load on the suspension. Based on research, recommendations for the use of the obtained optimal start-up mode have been developed.

Key words: turning mechanism, reach change mechanism, cargo swing, steady change of reach, integrated functionality, turn mode optimization.

Ловейкин В. С., Паламарчук Д. А., Ромасевич Ю. А., Ловейкин А. В.

ОПТИМИЗАЦИЯ РЕЖИМА ПОВОРОТА КРАНА ПРИ УСТАНОВИВШЕМСЯ ИЗМЕНЕНИИ ВЫЛЕТА ШАРНИРНО-СОЧЛЕНЕННОЙ СТРЕЛОВОЙ СИСТЕМЫ С ЗУБЧАТЫМ СЕКТОРОМ

Приведены результаты оптимизации режима поворота шарнирно-сочлененной стреловой системы крана на участке пуска, при установившемся режиме изменения вылета. За объект исследования использована стреловая система с секторным приводом механизма изменения вылета, механизм поворота состоит из электродвигателя, планетарного механизма и зубчатой передачи. Для оптимизации режима поворота стреловой системы использованы методы вариационного исчисления. При этом, сформировано вариационную задачу, которая включает уравнения движения стреловой системы при повороте и изменении вылета, критерий оптимизации и краевые условия движения. Критерий оптимизации имеет вид интегрального функционала, отражает среднее значение движущего

момента приводного механизма поворота за время пуска. Исследование проведено при пуске двигателя механизма поворота от состояния покоя до достижения номинальной частоты вращения, и при постоянной скорости вращения двигателя в механизме изменения вылета.

Решение задачи представлено в виде полинома с двумя слагаемыми, первый из которых обеспечивает краевые условия движения, а второй минимизирует критерий оптимизации по неизвестным коэффициентам. Для этого использована программа, основанная на симплекс методе. Построены графики изменения кинематических характеристик груза и стреловой системы при работе механизмов поворота и изменения вылета, а также движущего момента в процессе пуска механизма поворота, которые соответствуют оптимальному режиму движения. Полученный режим движения позволил устранить колебания груза и минимизировать воздействие динамических нагрузок. Разработаны рекомендации по использованию полученного оптимального режима пуска.

Ключевые слова: механизм поворота, механизм изменения вылета, раскачивание груза, устоявшееся изменение вылета, интегральный функционал, оптимизация режима поворота.

УДК 621.87

Ловеikin В. С., Паламарчук Д. А., Ромасевич Ю. О., Ловеikin А. В. Оптимізація режиму повороту крана при усталеній зміні вильоту шарнірно-зчленованої стрілової системи із зубчастим сектором // Опір матеріалів і теорія споруд: наук.-тех. збірник. – К.: КНУБА, 2021. – Вип. 106. – С. 221-235.

Наведено результати оптимізації режиму повороту шарнірно-зчленованої стрілової системи крана на ділянці пуску, при усталеному режимі зміні вильоту. За об'єкт дослідження використано стрілову систему з секторним приводом механізму змін вильоту, а механізм повороту складається з електродвигуна, планетарного механізму та відкритої зубчастої передачі. Для оптимізації режиму повороту стрілової системи використані методи варіаційного числення. Розв'язок задачі представлено у вигляді полінома з двома доданками. Для цього використано пакет програм, що базується на симплекс методі.

Ил. 6. Библиогр. 15 назв.

UDC 539.3

Loveykin V.S., Palamarchuk D.A., Romasevich Yu.O., Loveykin A.V. Optimization of rotate mode at constant change of departure in the level-luffing crane with geared sector // Strength of Materials and Theory of Structures: Scientific-and-technical collected articles – Kyiv: KNUBA, 2021. – Issue 106. – P. 221-235.

The results of optimization of the rotation mode of the level-luffing boom system of the crane at the launch site, with the steady-state mode of departure change. The object of the study is a boom system with a sector drive of the mechanism of change of departure, and the mechanism of rotation consists of an electric motor, a planetary mechanism and an open gear. Variation calculus methods were used to optimize the mode of rotation of the boom system. The solution of the problem is presented in the form of a polynomial with two terms. To do this, use a software package based on the simplex method.

Ил. 6. Ref. 15.

Ловеikin В. С., Паламарчук Д. А., Ромасевич Ю. А., Ловеikin А. В. Оптимізація режиму повороту крана при установившемся изменении вылета шарнірно-сочлененной стреловой системы с зубчатым сектором // Сопротивление материалов и теория сооружений. – К.: КНУБА, 2021. – Вип. 106. – С. 221-235.

Приведены результаты оптимизации режима поворота шарнірно-сочлененной стреловой системы крана на участке пуска, при установившемся режиме изменения вылета. За объект исследования использовано стреловую систему с секторным приводом механизма изменения вылета, а механізм поворота состоит из электродвигателя, планетарного механизма и открытой зубчатой передачи. Для оптимізації режиму поворота стреловой системы использованы методы вариационного исчисления. Решение задачи представлено в виде полинома с двумя слагаемыми. Для этого использован пакет программ, основанный на симплекс методе.

Ил. 6. Библиогр. 15 назв.

Автор (науковий ступінь, вчене звання, посада): доктор технічних наук, професор, завідувач кафедри конструювання машин і обладнання Національного університету біоресурсів і природокористування України ЛОВЕЙКІН Вячеслав Сергійович

Адреса робоча: 03041 Україна, м. Київ, вул. Героїв Оборони, 12, Національний університет біоресурсів і природокористування України, кафедра конструювання машин і обладнання, ЛОВЕЙКІНУ Вячеславу Сергійовичу.

Робочий тел.: +38(044) 527-87-34;

Мобільний тел.: +38(097) 349-14-53;

E-mail: lovvs@ukr.net

ORCID ID: <https://orcid.org/0000-0003-4259-3900>

Автор (науковий ступінь, вчене звання, посада): кандидат технічних наук, доцент, доцент кафедри теоретичної механіки КНУБА ПАЛАМАРЧУК Дмитро Анатолійович.

Адреса робоча: 03037 Україна, м. Київ, Повітрофлотський проспект 31, КНУБА, кафедра теоретичної механіки, ПАЛАМАРЧУКУ Дмитру Анатолійовичу.

Мобільний тел.: +38(097) 825-73-35;

E-mail: palamarchuk-dima@ukr.net

ORCID ID: <https://orcid.org/0000-0002-8019-9659>

Автор (науковий ступінь, вчене звання, посада): доктор технічних наук, доцент, професор кафедри конструювання машин і обладнання Національного університету біоресурсів і природокористування України РОМАСЕВИЧ Юрій Олександрович.

Адреса робоча: 03041 Україна, м. Київ, вул. Героїв Оборони, 12, Національний університет біоресурсів і природокористування України, кафедра конструювання машин і обладнання, РОМАСЕВИЧУ Юрію Олександровичу.

Робочий тел.: +38(044) 527-87-34;

E-mail: romasevichyuriy@ukr.net

ORCID ID: <https://orcid.org/0000-0001-5069-5929>

Автор (науковий ступінь, вчене звання, посада): кандидат фізико-математичних наук, доцент, доцент кафедри математичної фізики Київського національного університету імені Тараса Шевченка ЛОВЕЙКІН Андрій Вячеславович

Адреса робоча: 03022, Україна, м. Київ, проспект академіка Глушкова, 4е, корпус механіко-математичного факультету, Київський національний університет імені Тараса Шевченка, кафедра математичної фізики, ЛОВЕЙКІНУ Андрію Вячеславовичу

Мобільний тел.: +38(097) 350-91-23;

E-mail: anlov74@gmail.com

ORCID ID: <https://orcid.org/0000-0002-7988-8350>